

Positioning system ALLM 203, 204

Linear motor drive

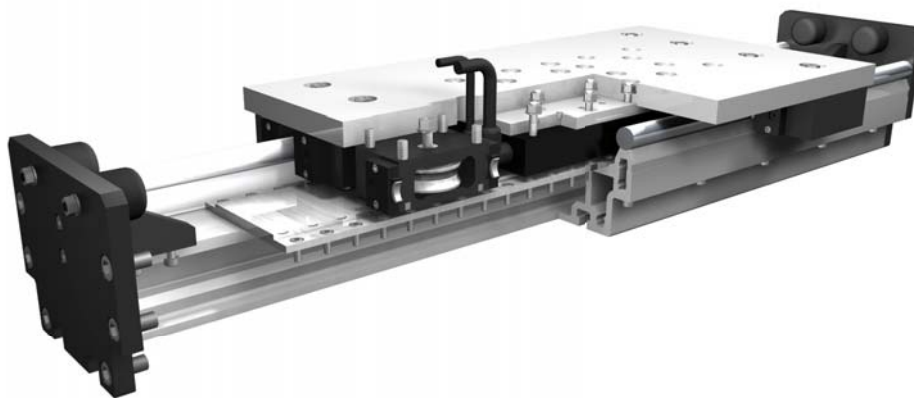

Function:

This unit consists of an aluminium profile with hardened steel spindles mounted on top of the profile. The carriage, which has internal linear ball bearings that can be adjusted free of play, moves along the unit. The linear-motor ALLM unit is based on the principle of a linear, synchronous AC motor.

The guiding profile is fitted with permanent magnets as stator. The carriage is fitted with the actuator. The magnetic attraction causes a force between carriage and guiding profile also in the absence of current. This force can be used for the initial tension of the bearings. Several carriages can be driven independently on one guiding profile.

Fitting position: As required. Max. length 6.400 mm without joints.

Carriage mounting: By tapped holes.

Unit mounting: By T-slots and mounting sets. The linear axis can be combined with any T-slot profile.

Carriage support: In the standard version, the carriage runs on 8 rollers which can be adjusted and serviced. For longer carriages the number of rollers can be increased. Repeatability $\pm 0,05$ mm.

Forces and torques

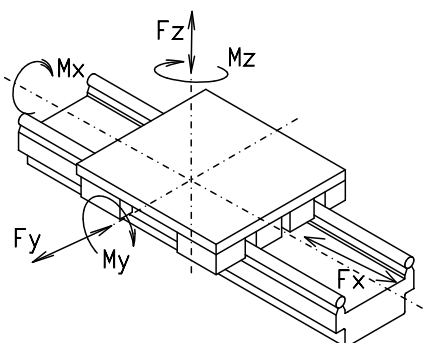

Size	ALLM 203		ALLM 204	
	static	dynamic	static	dynamic
Forces/Torques				
F_x (N)	23000	18400	30000	24000
F_y (N)	11000	8800	16250	13000
M_x (Nm)	1200	950	1870	1500
M_x (Nm) Motor 1	3060	2450	5000	4000
M_y (Nm) Motor 1	6250	5100	9500	7600
M_x (Nm) Motor 2	4010	3210	6520	5220
M_y (Nm) Motor 2	8340	6670	12180	9750
All forces and torques related to the following:				
existing values	$\frac{F_y}{F_{y_{dyn}}} + \frac{F_z}{F_{z_{dyn}}} + \frac{M_x}{M_{x_{dyn}}} + \frac{M_y}{M_{y_{dyn}}} + \frac{M_z}{M_{z_{dyn}}} \leq 1$			
table values				
Transverse force without current				
N	35		45	
Moved mass (g) without motor	43	48	55	62
Speed				
Motor size / weight (kg)	1 / 17,2	2 / 25,5	1 / 17,2	2 / 25,5
(m/sec) max	8	8	8	8
Thrust				
permanent (N)	2600	3900	2600	3900
Max. (N)	4000	6010	4000	6010
Geometrical moments of inertia of aluminium profile				
I_x mm ⁴	$2,26 \times 10^7$		$2,98 \times 10^7$	
I_y mm ⁴	$8,75 \times 10^7$		$10,22 \times 10^7$	
Elastic modulus N/mm ²	70000		70000	

Formula: ALLM

$$f = \frac{F \cdot L^3}{E \cdot I \cdot 192}$$

f = deflection (mm)
 F = load (N)
 L = free length (mm)
 E = elastic modulus 70000 (N/mm²)
 I = second moment of area (mm⁴)

Positioning system ALLM 203, 204

Dimensions (mm)

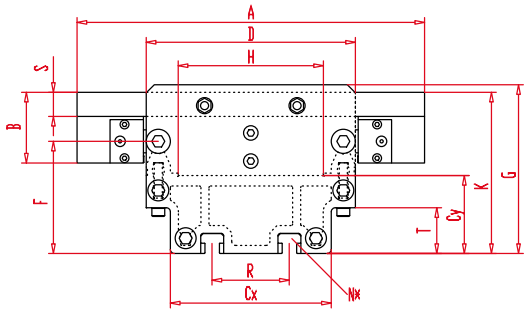

Increasing the carriage length will increase the basic length by the same amount.

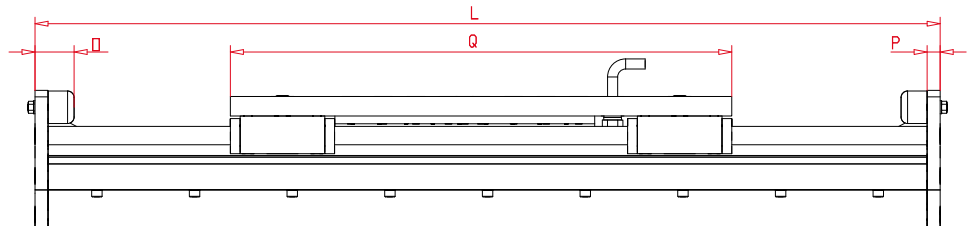
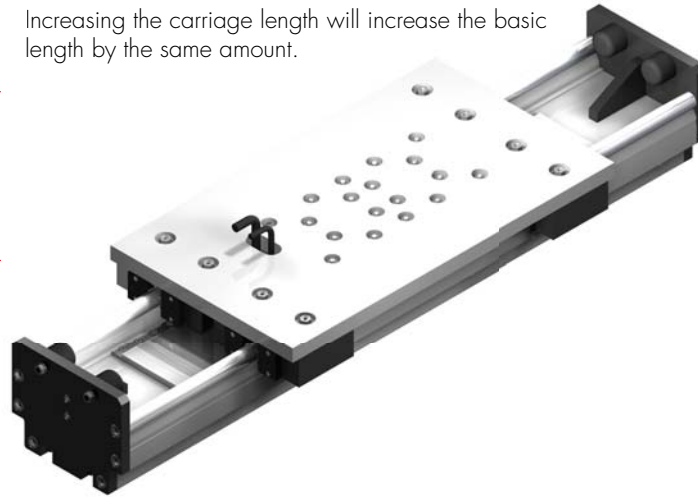

Size	Basic length L motor size 1 / 2	A	B	Cx	Cy	D	F	G	H	K	N for	O	P	Q motor size 1 / 2	R	S	T	Basic weight motor size 1 / 2	Weight per 100 mm
ALLM 203	865/1050	432	88	200	97	260	139,6	210	180,5	200,5	M16	60	20	745/930	96	30	57	110 / 136 kg	5,6 kg
ALLM 204	925/1110	480	102,5	200	97	270	139,6	210	180,5	217,5	M16	60	20	805/990	96	30	57	136 / 163 kg	6,5 kg

Guide rod size:

(3) Ø=30 **(4)** Ø=40

Choice of guide body profile:

(0) Standard **(2)** corrosion-protected guide rods and screws
(4) expanded corrosion-protected version (depending on the availability of components)

Measurement system:

(1) Measurement system LE100 5V Resolution 0.05 **(2)** Measurement system LE100 10,5-30V Resolution 0.05 **(3)** Hall sensor **(4)** Measurement system provided by customer

Motor size:

(0) Motor size 1
(1) Motor size 2
(2) without Motor, for Motorsize 1
(3) without Motor, for Motorsize 2

Basic length + stroke = total length

ALLM 20	3	0	0	1	0	0	0	0	0	2000
Pos.	1	2	3	4	5	6	7			

Sample ordering code:

ALLM203, guide rods 30 mm, standard body profile, Measurement system LE100 5V, motor size 1, 1135 mm stroke.

