



APEX DYNAMICS, INC.



PE/PG/PN/PB
SERIES

Planetary Gearboxes

PE/PG/PN/PB Series

Characteristic Highlights

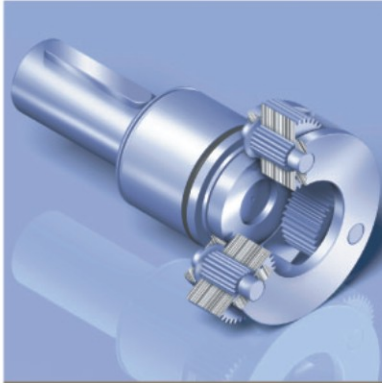

One piece planet carrier and planet gearing is supported on both sides. Provide maximum radial load capacity and increase system reliability and stiffness.

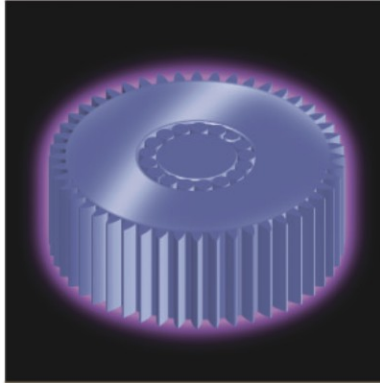

Equipped with *solid uncaged needle roller bearings*, provides maximum contact points to increase stiffness and generates high output torque. *Our in-house plasma nitriding* heat treatment process maintains the tooth surface hardness at **900Hv** for superior wear-resistance and a core hardness at **30 HRC** for toughness.

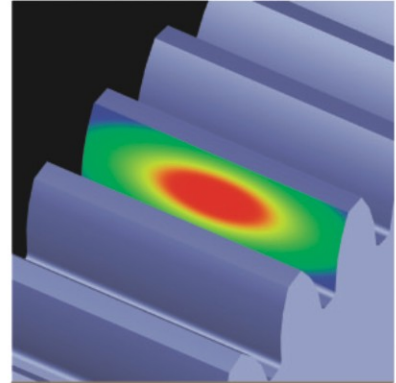

A high setting gear performance is achieved by using our *HeliTopo technology*. This *eases off the tooth profile and crowns the lead of each tooth*. This optimizes the gear mesh alignment and overlap to achieve maximum tooth surface contact.

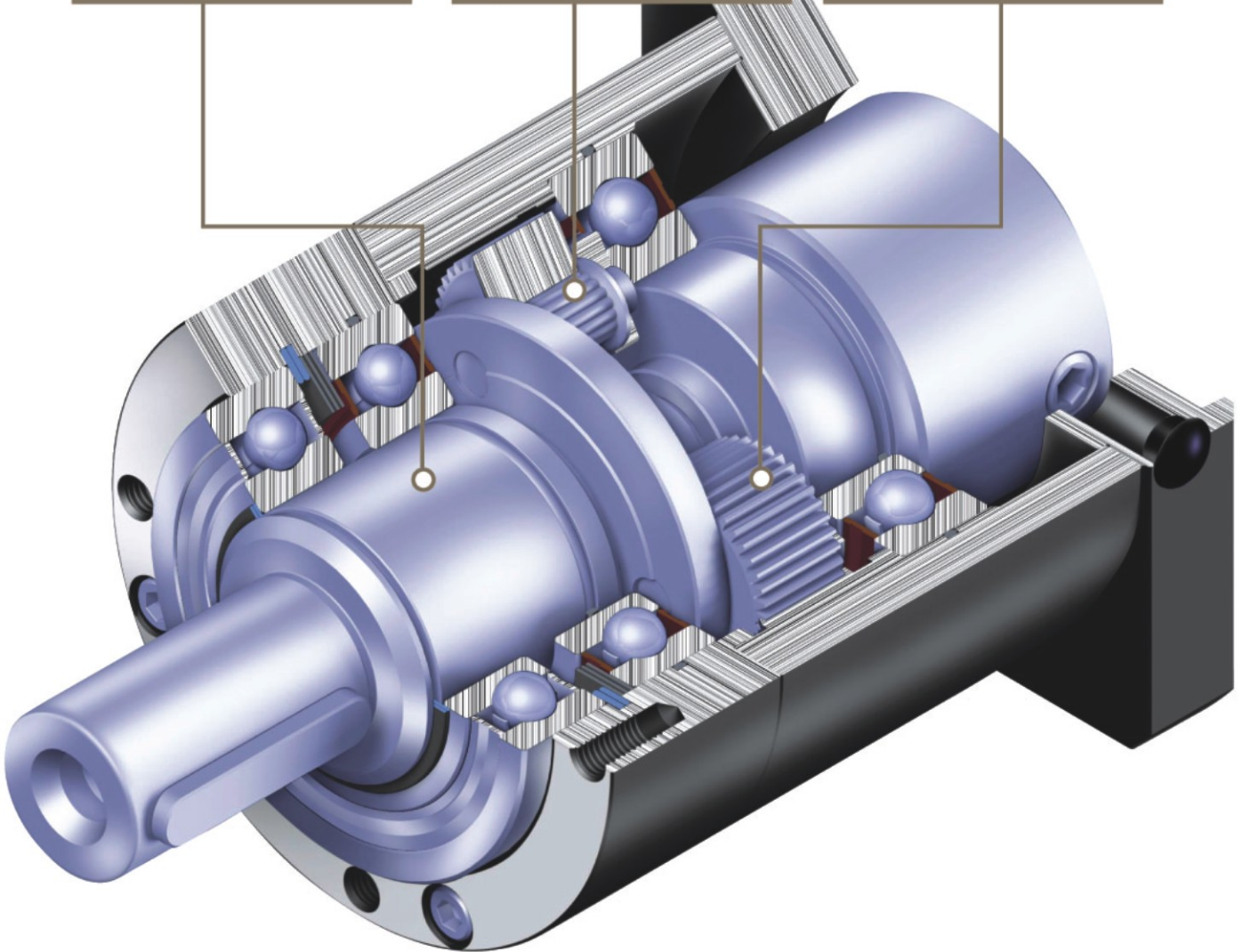

Permitted Radial and Axial Loads on Output Shaft of the Gearbox

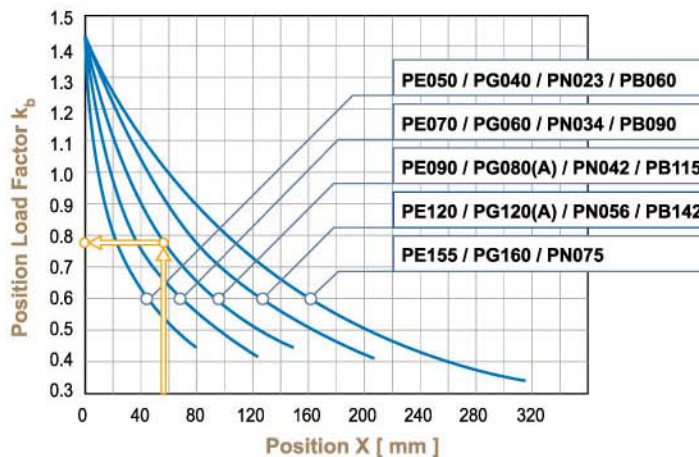
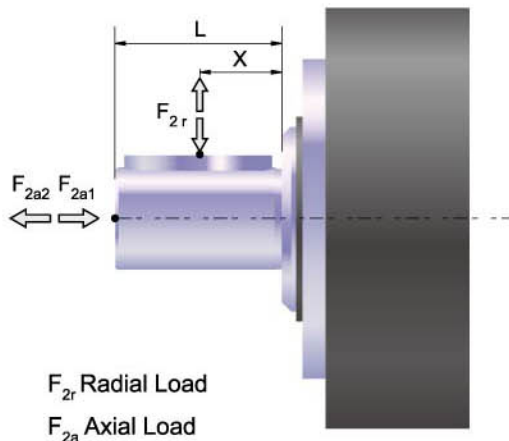

The permitted radial and axial loads on output shaft of the gearbox depend on the design of the gearbox supporting bearings.

If radial force F_{2r} is not exerted on the center of the output shaft $X < 1/2xL$ or $X > 1/2xL$. The permitted radial and axial loads can be calculated by the position load factor k_b on the above diagram.

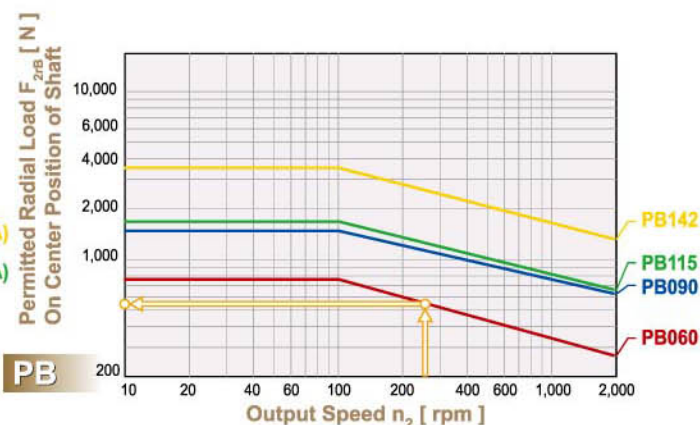
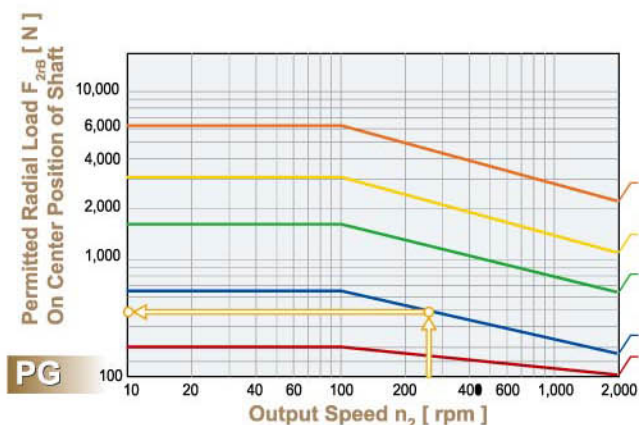
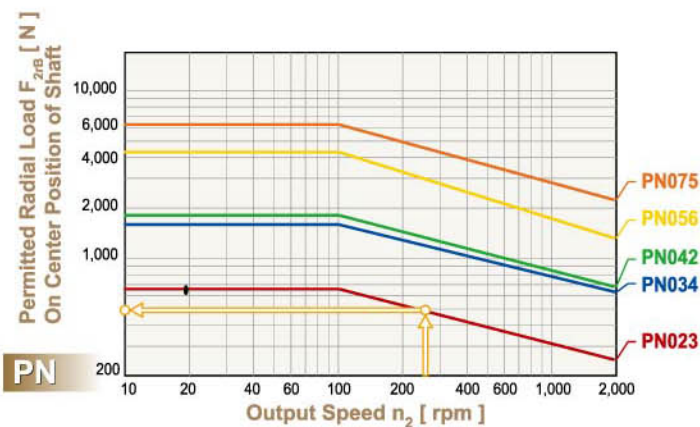
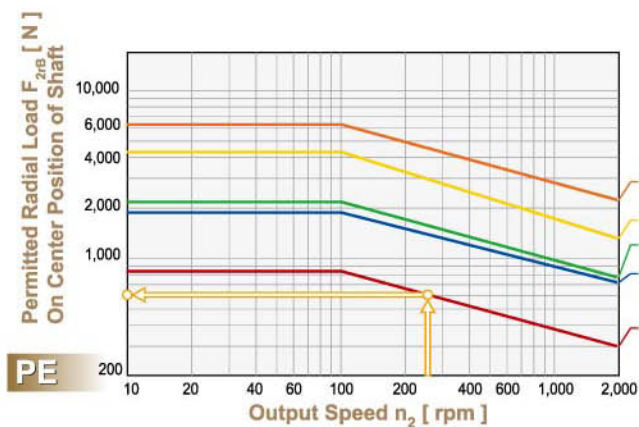

If radial force F_{2r} exert on the center of the output shaft $X = 1/2xL$. Under various operating condition the lifetime is over 20,000* hours. The permitted radial load is given on the above diagram.

*Continuous operation reduces service life by 50%

PE Series Specifications

Gearbox Performance

Model No.	Stages	Ratio ¹	PE050	PE070	PE090	PE120	PE155		
Nominal Output Torque T_{2N}	1	3	14	39	104	215	423		
		4	12	31	85	176	364		
		5	14	39	104	215	423		
		7	12	33	91	195	358		
		10	9	26	65	150	293		
	Nm	2	15	14	39	104	215	423	
			16	12	31	85	176	364	
			20	12	31	85	176	364	
			25	14	39	104	215	423	
			30	14	39	104	215	423	
				35	12	33	91	195	358
				40	12	31	85	176	364
				50	14	39	104	215	423
				70	12	33	91	195	358
				100	9	26	65	150	293
Max. Output Torque T_{2B}	Nm	1,2	3~100	3 times of Nominal Output Torque					
Nominal Input Speed n_{1N}	rpm	1,2	3~100	4,500	4,000	3,600	3,000	2,500	
Max. Input Speed n_{1B}	rpm	1,2	3~100	8,000	6,000	6,000	4,800	3,600	
Backlash*	arcmin	1	3~10	≤ 8	≤ 8	≤ 6	≤ 6	≤ 6	
		2	15~100	≤ 10	≤ 10	≤ 8	≤ 8	≤ 8	
Torsional Rigidity	Nm/arcmin	1,2	3~100	2	4.4	13.5	35.6	64	
Max. Radial Load F_{2RB^2}	N	1,2	3~100	820	1,910	2,060	4,160	6,450	
Max. Axial Load F_{2aB^2}	N	1,2	3~100	410	955	1,030	2,080	3,225	
Service Life	hr	1,2	3~100	20,000*					
Efficiency η	%	1	3~10	≥ 97%					
		2	15~100	≥ 94%					
Weight	kg	1	3~10	0.8	1.9	3.8	8.9	18.0	
		2	15~100	1.1	2.7	5.2	12.2	24.6	
Operating Temp	°C	1,2	3~100	0°C~+90°C					
Lubrication		1,2	3~100	CASTROL LMX Grease					
Degree of Gearbox Protection		1,2	3~100	IP64					
Mounting Position		1,2	3~100	all directions					
Noise Level ($n_1=3,000$ rpm)	dB	1,2	3~100	≤ 68	≤ 70	≤ 72	≤ 74	≤ 75	

Gearbox Inertia

Model No.	Stages	Ratio ¹	PE050	PE070	PE090	PE120	PE155		
Mass Moments of Inertia J_1	1	3	0.16	0.63	3.48	12.84	36.72		
		4	0.16	0.60	3.31	12.22	34.63		
		5	0.16	0.59	3.28	12.10	34.24		
		7	0.16	0.59	3.27	12.05	34.07		
		10	0.16	0.59	3.26	12.03	34.02		
	kg·cm ²	2	15	0.16	0.59	3.28	12.10	34.24	
			16	0.16	0.60	3.31	12.22	34.63	
			20	0.16	0.59	3.28	12.10	34.24	
			25	0.16	0.59	3.28	12.10	34.24	
			30	0.16	0.59	3.26	12.03	34.02	
				35	0.16	0.59	3.28	12.10	34.24
				40	0.16	0.59	3.26	12.03	34.02
				50	0.16	0.59	3.26	12.03	34.02
				70	0.16	0.59	3.26	12.03	34.02
				100	0.16	0.59	3.26	12.03	34.02

1. Ratio ($i=N_{in}/N_{out}$)

*Service life for cycloid duty (S5) is 20,000 hrs, for continuous duty (S1) is reduced by 50%.

*Backlash is measured at 2% of Nominal Output Torque T_{2N}

2. Applied to the output shaft center @100rpm

PE Series Dimension

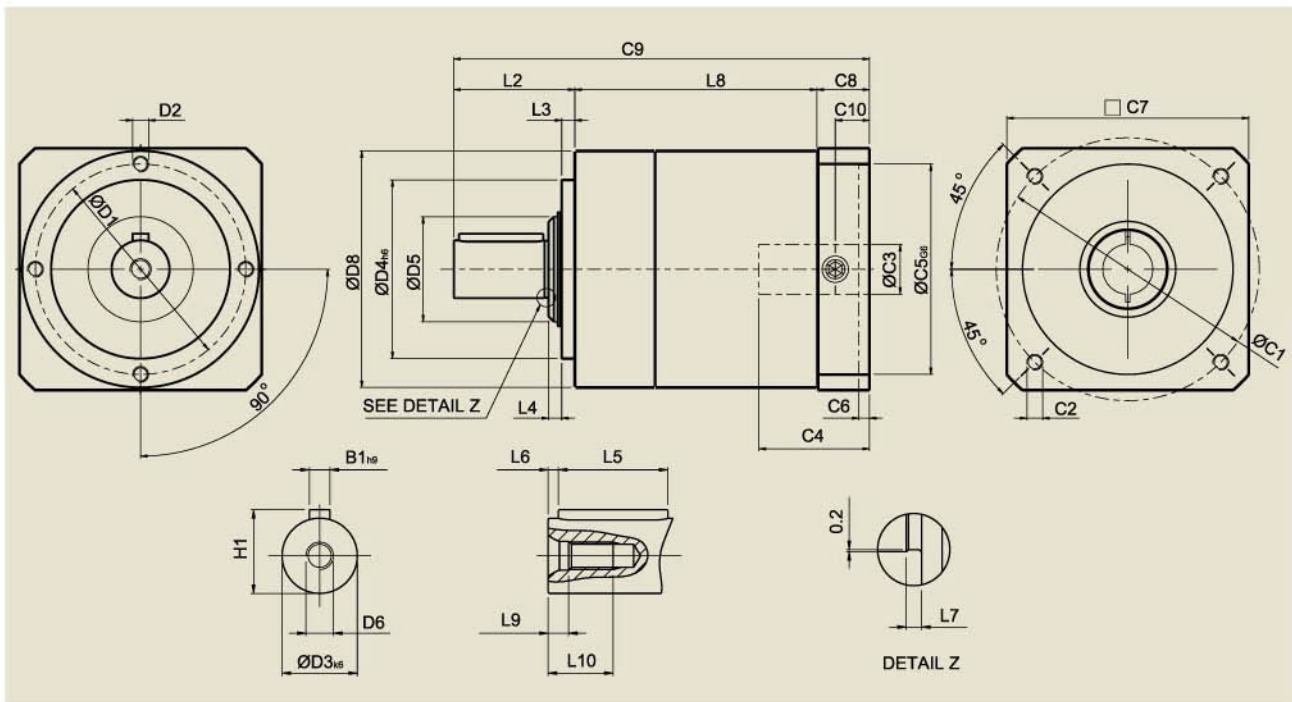

[unit: mm]

Dimension	PE050	PE070	PE090	PE120	PE155
D1	44	62	80	108	140
D2	M4X9	M5X10	M6X12	M8X15	M10X18
D3 _{K6}	12	16	22	32	40
D4 _{h6}	35	52	68	90	120
D5	17	25	40	50	65
D6	M4X0.7P	M5X0.8P	M8X1.25P	M12X1.75P	M16X2P
D8	50	70	90	120	155
L2	24.5	36	46	70	97
L3	4	5	5	6	8
L4	2.5	3	5	6	7
L5	14	25	32	50	70
L6	2	2	2	4	6
L7	1	1	1.5	2	2
L8	1-stage	55	77	92	127
	2-stage	79.5	110	131.5	180
L9	4.5	4.8	7.2	10	12
L10	10	12.5	19	28	36
C1	46	70	100	130	165
C2	M4X0.7P	M5X0.8P	M6X1P	M8X1.25P	M10X1.5P
C3	≤ 12	≤ 16	≤ 24	≤ 32	≤ 38
C4	30	34	40	50	60
C5 _{G6}	30	50	80	110	130
C6	3.5	8	4	5	6
C7	52	72	92	122	157
C8	21.5	21.5	20	24	31
C9	1-stage	101	134.5	158	221
	2-stage	125.5	167.5	197.5	274
C10	14.5	15.5	13	16	21
B1 _{h9}	4	5	6	10	12
H1	13.5	18	24.5	35	43

3.C1-C10 are motor specific dimensions (metric std shown). Refer to Apexdyna.com and Design Tool to view your specific motor mounting system.

PG(PGA) Series Specifications

Gearbox Performance

Model No.	Stages	Ratio ¹	PG040	PG060	PG080	PG080A	PG120	PG120A	PG160	
Nominal Output Torque T_{2N}	1	3	14	39	104	215	423			
		4	12	31	85	176	364			
		5	14	39	104	215	423			
		7	12	33	91	195	358			
		10	9	26	65	150	293			
		2	15	14	39	104	215	423		
			16	12	31	85	176	364		
			20	12	31	85	176	364		
			25	14	39	104	215	423		
			30	14	39	104	215	423		
	35		12	33	91	195	358			
	40		12	31	85	176	364			
	50		14	39	104	215	423			
	70	12	33	91	195	358				
	100	9	26	65	150	293				
	Max. Output Torque T_{2B}	Nm	1,2	3~100	3 times of Nominal Output Torque					
	Nominal Input Speed n_{1N}	rpm	1,2	3~100	4,500	4,000	3,600	3,000	2,500	
	Max. Input Speed n_{1B}	rpm	1,2	3~100	8,000	6,000	6,000	4,800	3,600	
Backlash*	arcmin	1	3~10	≤ 8	≤ 8	≤ 6	≤ 6	≤ 6		
		2	15~100	≤ 10	≤ 10	≤ 8	≤ 8	≤ 8		
Torsional Rigidity	Nm/arcmin	1,2	3~100	0.8	2.2	7.2	14.5	65.5		
Max. Radial Load F_{2rB}^2	N	1,2	3~100	300	680	1,750	3,080	6,520		
Max. Axial Load F_{2aB}^2	N	1,2	3~100	150	340	875	1,540	3,260		
Service Life	hr	1,2	3~100	20,000*						
Efficiency η	%	1	3~10	≥ 97%						
		2	15~100	≥ 94%						
Weight	kg	1	3~10	0.7	1.7	3.6	3.6	8.1	8.2	18.2
		2	15~100	1.0	2.4	5.0	5.0	11.3	11.4	24.9
Operating Temp	°C	1,2	3~100	0°C~+90°C						
Lubrication		1,2	3~100	CASTROL LMX Grease						
Degree of Gearbox Protection		1,2	3~100	IP64						
Mounting Position		1,2	3~100	all directions						
Noise Level ($n_1=3,000$ rpm)	dB	1,2	3~100	≤ 68	≤ 70	≤ 72	≤ 74	≤ 75		

Gearbox Inertia

Model No.	Stages	Ratio ¹	PG040	PG060	PG080	PG080A	PG120	PG120A	PG160	
Mass Moments of Inertia J_1	1	3	0.16	0.63	3.48	12.84	36.72			
		4	0.16	0.60	3.31	12.22	34.63			
		5	0.16	0.59	3.28	12.10	34.24			
		7	0.16	0.59	3.27	12.05	34.07			
		10	0.16	0.59	3.26	12.03	34.02			
		2	15	0.16	0.59	3.28	12.10	34.24		
			16	0.16	0.60	3.31	12.22	34.63		
			20	0.16	0.59	3.28	12.10	34.24		
			25	0.16	0.59	3.28	12.10	34.24		
			30	0.16	0.59	3.26	12.03	34.02		
	35		0.16	0.59	3.28	12.10	34.24			
	40		0.16	0.59	3.26	12.03	34.02			
	50		0.16	0.59	3.26	12.03	34.02			
	70	0.16	0.59	3.26	12.03	34.02				
	100	0.16	0.59	3.26	12.03	34.02				

1. Ratio ($i=N_{in}/N_{out}$)

*Service life for cycloid duty (S5) is 20,000 hrs, for continuous duty (S1) is reduced by 50%.

*Backlash is measured at 2% of Nominal Output Torque T_{2N}

2. Applied to the output shaft center @100rpm

PG(PGA) Series Dimension

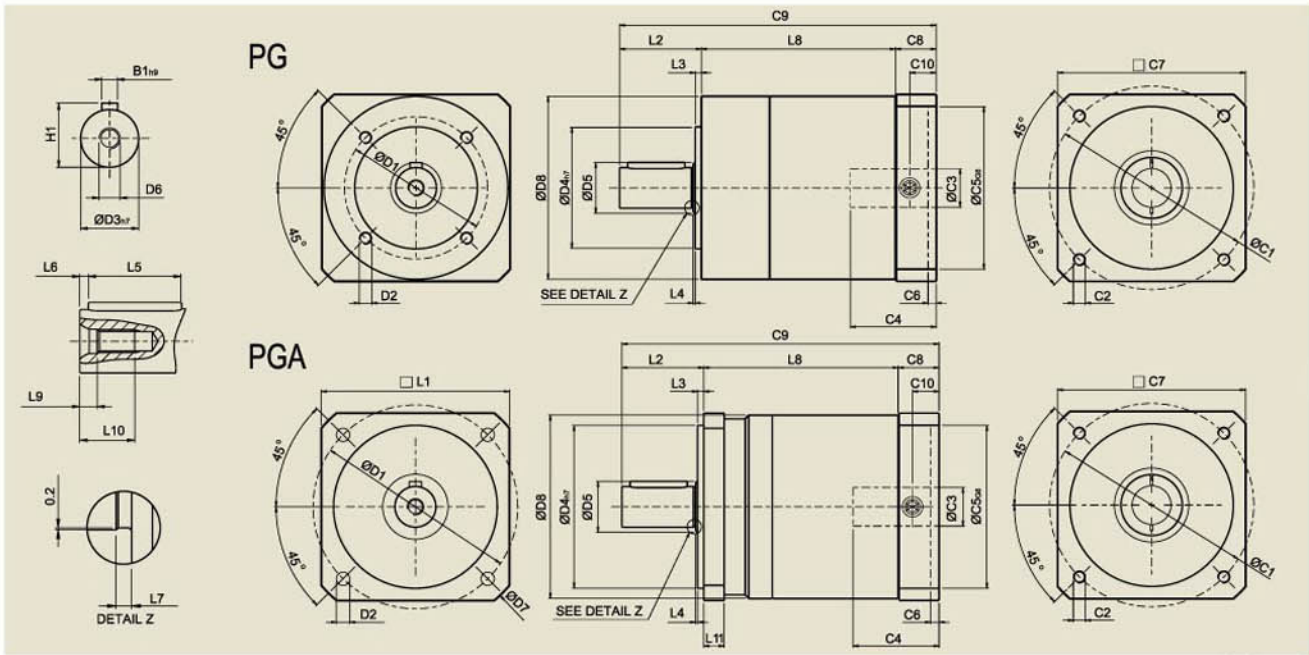

[unit: mm]

Dimension	PG040	PG060	PG080	PG080A	PG120	PG120A	PG160
D1	34	52	70	100	100	130	145
D2	M4X9	M5X10	M6X12	6.5	M10X18	8.5	M12X22
D3 _{h7}	10	14	20	20	25	25	40
D4 _{h7}	26	40	60	80	80	110	130
D5	12	17	25	25	35	35	65
D6	M3X0.5P	M5X0.8P	M6X1P	M6X1P	M10X1.5P	M10X1.5P	M16X2P
D7	-	-	-	120	-	167.5	-
D8	50	70	90	90	120	120	160
L1	-	-	-	92	-	124	-
L2	26	35	40	40	55	55	87
L3	2	3	3	3	4	4	5
L4	1	2	1	1	1	1	2
L5	18	25	28	28	40	40	65
L6	2.5	2.5	4	4	5	5	8
L7	1	1	1	1	1.5	1.5	2
L8	1-stage	50	68.5	95	125	125	153
	2-stage	74.5	101.5	134.5	178	178	213.5
L9	2.2	4.8	5	5	6.5	6.5	12
L10	9.5	12.5	16.5	16.5	23	23	36
L11	-	-	-	10	-	15	-
C1	46	70	100	100	130	130	165
C2	M4X0.7P	M5X0.8P	M6X1P	M6X1P	M8X1.25P	M8X1.25P	M10X1.5P
C3	≤ 12	≤ 16	≤ 24	≤ 24	≤ 32	≤ 32	≤ 38
C4	30	34	40	40	50	50	60
C5 _{G6}	30	50	80	80	110	110	130
C6	3.5	8	4	4	5	5	6
C7	52	72	92	92	122	122	157
C8	21.5	21.5	20	20	24	24	31
C9	1-stage	97.5	125	155	204	204	271
	2-stage	122	158	194.5	257	257	331.5
C10	14.5	15.5	13	13	16	16	21
B1 _{h9}	3	5	6	6	8	8	12
H1	11.2	16	22.5	22.5	28	28	43

3.C1-C10 are motor specific dimensions (metric std shown). Refer to Apexdyna.com and Design Tool to view your specific motor mounting system.

PN Series Specifications

Gearbox Performance

Model No.	Stages	Ratio ¹	PN023	PN034	PN042	PN056	PN075		
Nominal Output Torque T_{2N}	1	3	14	39	104	215	423		
		4	12	31	85	176	364		
		5	14	39	104	215	423		
		7	12	33	91	195	358		
		10	9	26	65	150	293		
	2	15	14	39	104	215	423		
		16	12	31	85	176	364		
		20	12	31	85	176	364		
		25	14	39	104	215	423		
		30	14	39	104	215	423		
		35	12	33	91	195	358		
		40	12	31	85	176	364		
		50	14	39	104	215	423		
		70	12	33	91	195	358		
	100	9	26	65	150	293			
	Max. Output Torque T_{2B}	Nm	1,2	3 times of Nominal Output Torque					
	Nominal Input Speed n_{1N}	rpm	1,2	3~100	4,500	4,000	3,600	3,000	2,500
	Max. Input Speed n_{1B}	rpm	1,2	3~100	8,000	6,000	6,000	4,800	3,600
Backlash*	arcmin	1	3~10	≤ 8	≤ 8	≤ 6	≤ 6	≤ 6	
		2	15~100	≤ 10	≤ 10	≤ 8	≤ 8	≤ 8	
Torsional Rigidity	Nm/arcmin	1,2	3~100	1.6	6.4	17.5	62.8	143.5	
Max. Radial Load F_{2rB}^2	N	1,2	3~100	680	1,770	1,830	4,410	6,440	
Max. Axial Load F_{2aB}^2	N	1,2	3~100	340	885	915	2,070	3,220	
Service Life	hr	1,2	3~100	20,000*					
Efficiency η	%	1	3~10	≥ 97%					
		2	15~100	≥ 94%					
Weight	kg	1	3~10	0.8	2.3	4.6	9.7	19.7	
		2	15~100	1.1	3.0	6.0	13.0	26.3	
Operating Temp	°C	1,2	3~100	0°C~+90°C					
Lubrication		1,2	3~100	CASTROL LMX Grease					
Degree of Gearbox Protection		1,2	3~100	IP64					
Mounting Position		1,2	3~100	all directions					
Noise Level ($n_1=3,000\text{rpm}$)	dB	1,2	3~100	≤ 68	≤ 70	≤ 72	≤ 74	≤ 75	

Gearbox Inertia

Model No.	Stages	Ratio ¹	PN023	PN034	PN042	PN056	PN075
Mass Moments of Inertia J_1	1	3	0.16	0.63	3.48	12.84	36.72
		4	0.16	0.60	3.31	12.22	34.63
		5	0.16	0.59	3.28	12.10	34.24
		7	0.16	0.59	3.27	12.05	34.07
		10	0.16	0.59	3.26	12.03	34.02
	2	15	0.16	0.59	3.28	12.10	34.24
		16	0.16	0.60	3.31	12.22	34.63
		20	0.16	0.59	3.28	12.10	34.24
		25	0.16	0.59	3.28	12.10	34.24
		30	0.16	0.59	3.26	12.03	34.02
		35	0.16	0.59	3.28	12.10	34.24
		40	0.16	0.59	3.26	12.03	34.02
		50	0.16	0.59	3.26	12.03	34.02
		70	0.16	0.59	3.26	12.03	34.02
	100	0.16	0.59	3.26	12.03	34.02	

1. Ratio ($i=N_{in}/N_{out}$)

*Service life for cycloid duty (S5) is 20,000 hrs, for continuous duty (S1) is reduced by 50%.

*Backlash is measured at 2% of Nominal Output Torque T_{2N}

2. Applied to the output shaft center @100rpm

PN Series Dimension

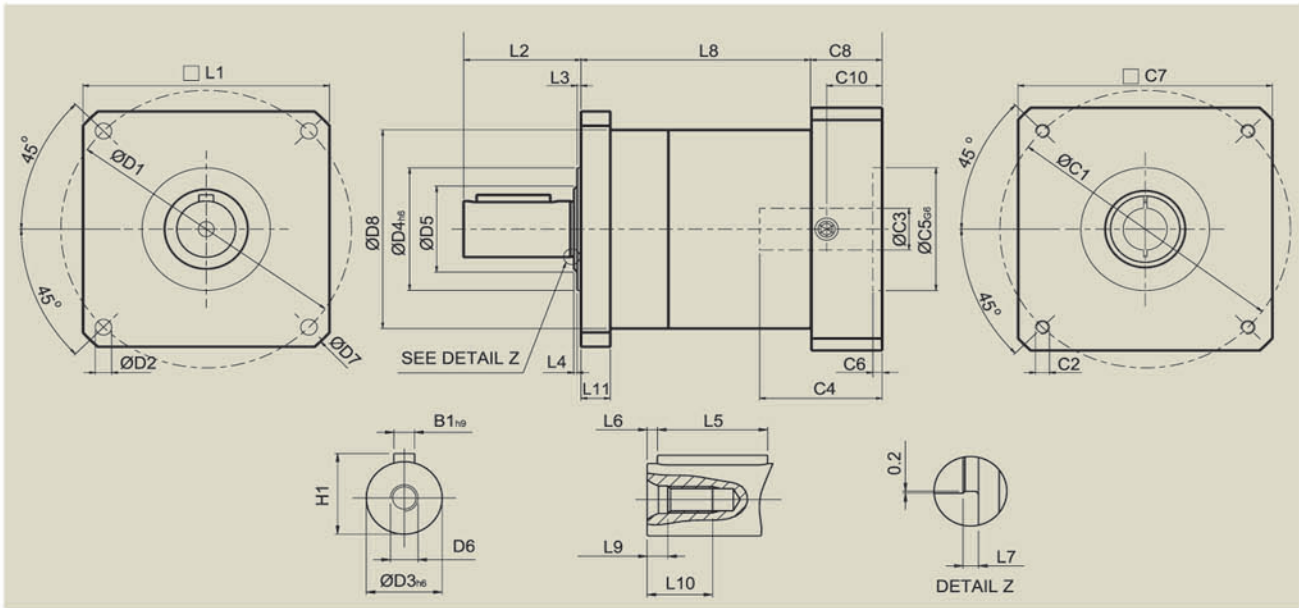

[unit: mm(inch)]

Dimension	PN023	PN034	PN042	PN056	PN075
D1	66.675(2.625)	98.425(3.875)	125.73(4.950)	177.8(7.0)	215.011(8.465)
D2	5.2(0.205)	5.6(0.220)	7.1(0.280)	10.4(0.409)	14.2(0.559)
D3 _{h8}	12.7(0.5)	19.05(0.750)	25.4(1.0)	38.1(1.5)	50.8(2.0)
D4 _{h8}	38.1(1.5)	73.025(2.875)	55.5(2.185)	114.3(4.5)	152.4(6.0)
D5	17	25	40	50	65
D6	M4X0.7P	M5X0.8P	M8X1.25P	M12X1.75P	M16X2P
D7	75	107.5	142	198	260
D8	50	70	90	120	155
L1	57.15(2.250)	82.55(3.250)	106.68(4.2)	146.05(5.750)	190(7.480)
L2	31.75	38.1	50.8	63.5	88.9
L3	1.6(0.063)	1.6(0.063)	1.6(0.063)	3.2(0.126)	4.75(0.187)
L4	1	1.5	1.5	2	2
L5	19.05(0.750)	25.4(1.0)	31.75(1.250)	38.1(1.5)	63.5(2.5)
L6	3.788(0.149)	3.8(0.150)	5.715(0.225)	8.563(0.337)	8.563(0.337)
L7	1	1	1.5	2	2
L8	1-stage	58.9	82	99.3	133.7
	2-stage	83.4	115	138.8	186.7
L9	4.5	4.8	7.2	10	12
L10	10	12.5	19	28	36
L11	6.4	7.9	12.7	19.05	22.2
C1	66.675(2.625)	98.425(3.875)	125.73(4.950)	149.225(5.875)	165
C2	M4X0.7P	M5X0.8P	M6X1P	11 Thru	M10X1.5P
C3	≤ 12	≤ 16	≤ 24	≤ 32	≤ 38
C4	32(1.260)	40(1.575)	51(2.008)	55(2.165)	60
C5 _{G6}	38.15(1.502)	73.08(2.877)	55.65(2.191)	114.3(4.5)	130
C6	3.5(0.138)	4(0.157)	4(0.157)	4(0.157)	6
C7	55(2.165)	85(3.346)	110(4.331)	130(5.118)	157
C8	23.5(0.925)	27.5(1.083)	31(1.220)	29(1.142)	31
C9	1-stage	114.15(4.494)	147.6(5.811)	181.1(7.130)	226.2(8.905)
	2-stage	138.65(5.459)	180.6(7.110)	220.6(8.685)	279.2(10.992)
C10	16.5(0.650)	21.5(0.846)	24(0.945)	21(0.827)	21
B1 _{h9}	3.175(0.125)	4.763(0.188)	6.35(0.250)	9.525(0.375)	9.525(0.375)
H1	14.125(0.556)	21.163(0.833)	28.2(1.110)	42.275(1.664)	55.125(2.170)

3.C1~C10 are NEMA motor specific dimensions(except for PN075). Refer to Apexdyna.com and Design Tool to view your specific motor mounting.

PB Series Specifications

Gearbox Performance

Model No.	Stages	Ratio ¹	PB060	PB090	PB115	PB142	
Nominal Output Torque T_{2N}	1	3	14	39	104	215	
		4	12	31	85	176	
		5	14	39	104	215	
		7	12	33	91	195	
		10	9	26	65	150	
	2	15	14	39	104	215	
		16	12	31	85	176	
		20	12	31	85	176	
		25	14	39	104	215	
		30	14	39	104	215	
		35	12	33	91	195	
		40	12	31	85	176	
		50	14	39	104	215	
		70	12	33	91	195	
	100	9	26	65	150		
	Max. Output Torque T_{2B}	Nm	1,2	3 times of Nominal Output Torque			
	Nominal Input Speed n_{1N}	rpm	1,2	3~100	4,500	4,000	3,600
Max. Input Speed n_{1B}	rpm	1,2	3~100	8,000	6,000	6,000	4,800
Backlash*	arcmin	1	3~10	≤ 8	≤ 8	≤ 6	≤ 6
		2	15~100	≤ 10	≤ 10	≤ 8	≤ 8
Torsional Rigidity	Nm/arcmin	1,2	3~100	3.7	7.2	15.1	60.5
Max. Radial Load F_{2rB}^2	N	1,2	3~100	770	1,750	1,890	3,720
Max. Axial Load F_{2aB}^2	N	1,2	3~100	385	875	945	1,860
Service Life	hr	1,2	3~100	20,000*			
Efficiency η	%	1	3~10	≥ 97%			
		2	15~100	≥ 94%			
Weight	kg	1	3~10	0.9	2.2	4.3	10.0
		2	15~100	1.2	3.0	5.7	13.3
Operating Temp	°C	1,2	3~100	0°C~+90°C			
Lubrication		1,2	3~100	CASTROL LMX Grease			
Degree of Gearbox Protection		1,2	3~100	IP64			
Mounting Position		1,2	3~100	all directions			
Noise Level ($n_1=3,000\text{rpm}$)	dB	1,2	3~100	≤ 68	≤ 70	≤ 72	≤ 74

Gearbox Inertia

Model No.	Stages	Ratio ¹	PB060	PB090	PB115	PB142
Mass Moments of Inertia J_1	1	3	0.16	0.63	3.48	12.84
		4	0.16	0.60	3.31	12.22
		5	0.16	0.59	3.28	12.10
		7	0.16	0.59	3.27	12.05
		10	0.16	0.59	3.26	12.03
	2	15	0.16	0.59	3.28	12.10
		16	0.16	0.60	3.31	12.22
		20	0.16	0.59	3.28	12.10
		25	0.16	0.59	3.28	12.10
		30	0.16	0.59	3.26	12.03
		35	0.16	0.59	3.28	12.10
		40	0.16	0.59	3.26	12.03
		50	0.16	0.59	3.26	12.03
		70	0.16	0.59	3.26	12.03
	100	0.16	0.59	3.26	12.03	

1. Ratio ($i=N_n/N_{out}$)

*Service life for cycloid duty (S5) is 20,000 hrs, for continuous duty (S1) is reduced by 50%.

*Backlash is measured at 2% of Nominal Output Torque T_{2N}

2. Applied to the output shaft center @100rpm

PB Series Dimension

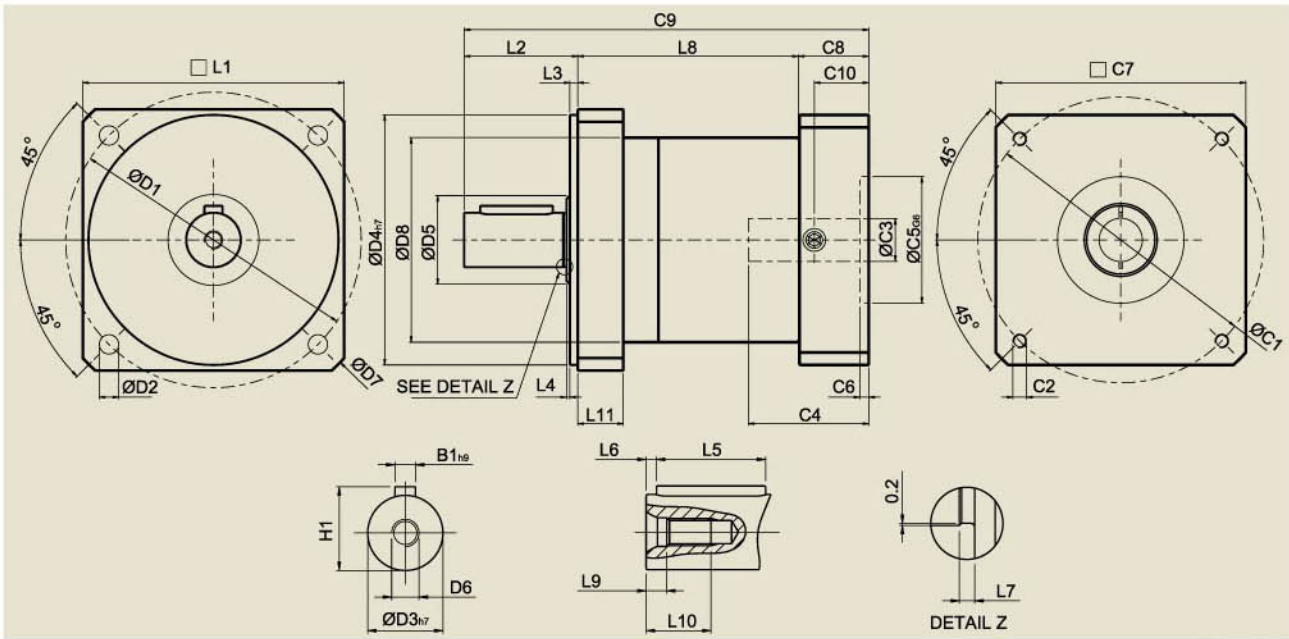

[unit: mm]

Dimension	PB060	PB090	PB115	PB142
D1	70	100	130	165
D2	5.5	6.5	9	11
D3 _{h7}	16	20	24	40
D4 _{h7}	50	80	110	130
D5	17	25	40	50
D6	M4X0.7P	M5X0.8P	M8X1.25P	M12X1.75P
D7	80	120	155	190
D8	50	70	90	120
L1	60	90	115	142
L2	25	40	50	80
L3	2.5	3	3.5	3.5
L4	1	1	1.5	1.5
L5	16	28	32	63
L6	3	5	7	8
L7	1	1	1.5	2
L8	1-stage	58	81	97
	2-stage	82.5	114	136.5
L9	4.5	4.8	7.2	10
L10	10	12.5	19	28
L11	13	17	20	25
C1	46	70	100	130
C2	M4X0.7P	M5X0.8P	M6X1P	M8X1.25P
C3	≤ 12	≤ 16	≤ 24	≤ 32
C4	30	34	40	50
C5 _{G6}	30	50	80	110
C6	3.5	8	4	5
C7	52	72	92	122
C8	21.5	21.5	20	24
C9	1-stage	104.5	142.5	167
	2-stage	129	175.5	206.5
C10	14.5	15.5	13	16
B1 _{h9}	5	6	8	12
H1	18	22.5	27	43

3.C1~C10 are motor specific dimensions (metric std shown). Refer to Apexdyna.com and Design Tool to view your specific motor mounting system.

PE / PG / PN / PB SERIES

Ordering Code

PE090

—

010

/

MOTOR

Gear Size:

PE: PE050, PE070, PE090, PE120, PE155

PG: PG040, PG060, PG080, PG080A, PG120, PG120A, PG160

PN: PN 023, PN034, PN042, PN056, PN075

PB: PB060, PB090, PB115, PB142

Ratio:

1 stage: 3, 4, 5, 7, 10

2 stage: 15, 16, 20, 25, 30, 35, 40, 50, 70, 100

Motor Designation:

Manufacture Type And Model

Ordering Example: PE090-010 / SIEMENS 1FT6 041-4AF71



APEX DYNAMICS, INC.

No. 6, 20th Rd., Taichung Industrial Park, Taichung, Taiwan, R.O.C.

Tel: 886 4 23550219 / Fax: 886 4 23550218

E-mail: sales@apexdyna.com

Website: www.apexdyna.com

APEX-2007-06-P-SERIES-1.1V

