

Linear system **ELZU 60 S W**

SURFACE PORTAL - STRENGTHENED CONSTRUCTION

3.1

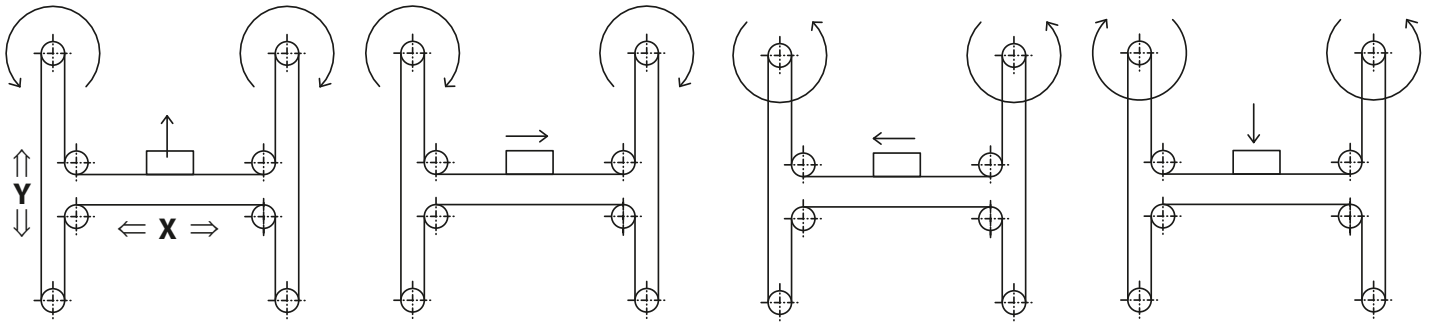

Function:

Surface gantry consisting of two Y axes and one X axis. The unit is driven by a rotating belt, which remains connected through various deflection points. Due to the rectangular profile high torques and loads can be taken up. In addition, a very high stability and low deflection are ensured for long axis systems. The belt tension can be easily readjusted via a tensioning device within the carriage. The movement is realised by two motors. The coordinate lies diagonal to the deflection points of the X axis. Advantage: Only small masses are moved and thus it is possible to achieve high accelerations.

Fitting position:

As required. Max. length and width 3.000 mm.

Carriage mounting:

By T-slots.

Unit mounting:

By T-slots or tapped holes in the bearing block, mounting sets.

Belt type:

HTD with steel reinforcement, no backlash when changing direction, repeatability: $\pm 0,1$ mm.

Forces and torques	Size		
	60 S		
	Forces/Torques		
		static	dynamic
	F_x (N)	894	800
	F_y (N)	4100	3100
	F_z (N)	2160	1600
	M_x (Nm)	88	65
	M_y (Nm)	190	140
M_z (Nm)	230	170	
All forces and torques relate to the following:			
existing values	$\frac{F_y}{F_{y_{dyn}}} + \frac{F_z}{F_{z_{dyn}}} + \frac{M_x}{M_{x_{dyn}}} + \frac{M_y}{M_{y_{dyn}}} + \frac{M_z}{M_{z_{dyn}}} \leq 1$		
table values			
No-load torque			
Nm	1,2		
Speed			
(m/s) max	5		
Tensile force			
permanent (N)	900		
0,2 s (N)	1000		
Geometrical moments of inertia of aluminium profile - Y-Axis			
I_y mm ⁴	6,79x10 ⁵		
I_z mm ⁴	6,97x10 ⁵		
E-Modul N/mm ²	70000		
Geometrical moments of inertia of aluminium profile - X-Axis			
I_x mm ⁴	2,8 x 10 ⁶		
I_y mm ⁴	9,6 x 10 ⁵		
E-Modulus N/mm ²	70000		

For life-time calculation of rollers use our homepage.

Driving torque:

$$M_o = \frac{F \cdot P \cdot S_i}{2000 \cdot \pi} + M_n$$

$$P_o = \frac{M_o \cdot n}{9550}$$

F = force (N)
 P = pulley action perimeter (mm)
 S_i = safety factor 1,2 ... 2
 M_n = no-load torque (Nm)
 n = rpm pulley (min⁻¹)
 M_o = driving torque (Nm)
 P_o = motor power (KW)

Deflection:

$$f = \frac{F \cdot L^3}{E \cdot I \cdot 192}$$

f = deflection (mm)
 F = load (N)
 L = free length (mm)
 E = elastic modulus 70000 (N/mm²)
 I = second moment of area (mm⁴)

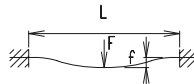

Linear system **ELZU 60 S W**

Dimensions (mm)

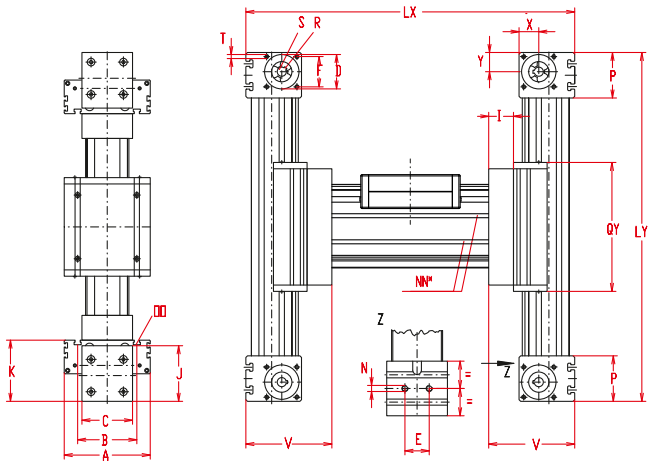

3.1

*For slide nuts refer to chapter 2.2 page 2

Size	Basic length		A	B	C	D -0,05	E	F	I	J	K	N for	NN for	OO for	P	Qx	Qy	T	V	X	Y	Basic weight	Weight per 100 mm
	Lx	Ly																					
ELZU 60 S W	450	400	170	108	80	47	30	42	33	82	94	M 8	M 5	M 8	59	194	280	M 6	127	27	26	17,9 kg	0,9 kg

0 Choice of guide body profile:

- (0) Standard (2) corrosion-protected guide rods and screws
- (4) expanded corrosion-protected version (depending on the availability of components)

0 Choice of carriages:

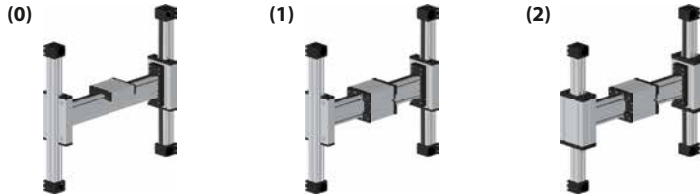

Size	Version 1				Version 2			
	Qx	Lx	Qy	Ly	Qx	Lx	Qy	Ly
60 S	214	470	280	400	214	470	300	420

0 Drive version:

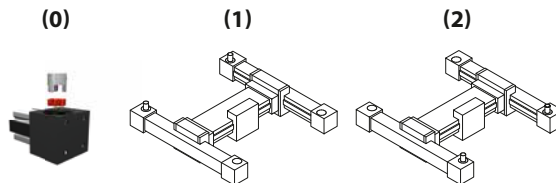

The standard version is supplied without shaft. A shaft can be retrofitted by inserting it into the pulley bore and securing it with 2 locking rings.

Belt table:

Code No.	Size	Belt	mm/rev.	Number of teeth
0 4	60 S	5M25	130	26

Shaft dimensions / Coupling claw:

Size	Shaft ø h6 x length	Key	Coupling
60 S	14 x 35	5x5x28	14

ELZU 60S W 7 0 0 0 0 4 1 01500

ELZU 60S W 8 0 0 0 0 4 1 00700

Pos. 1 2 3 4 5 6 7

X-Axis Basic length + stroke = total length
Y-Axes Basic length + stroke = total length

For combination kits and connecting elements refer to chapter 2.2

Sample ordering code:

ELZU 60S W, standard body profile, standard carriage, coupling claw on one side, stroke X = 1080 / Y = 298 mm

