

Positioning system ELZA 40 / ELDZA 60, 60S, 80, 80S, 100

Rack and pinion drive

Specifications

4.1



ELZA 40

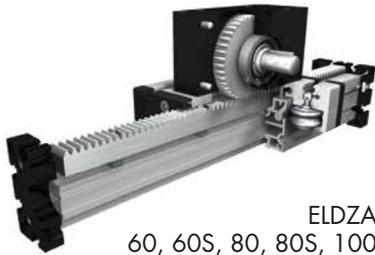

ELDZA
60, 60S, 80, 80S, 100

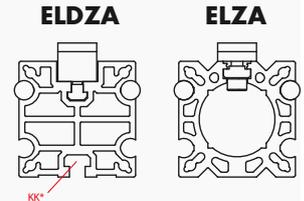
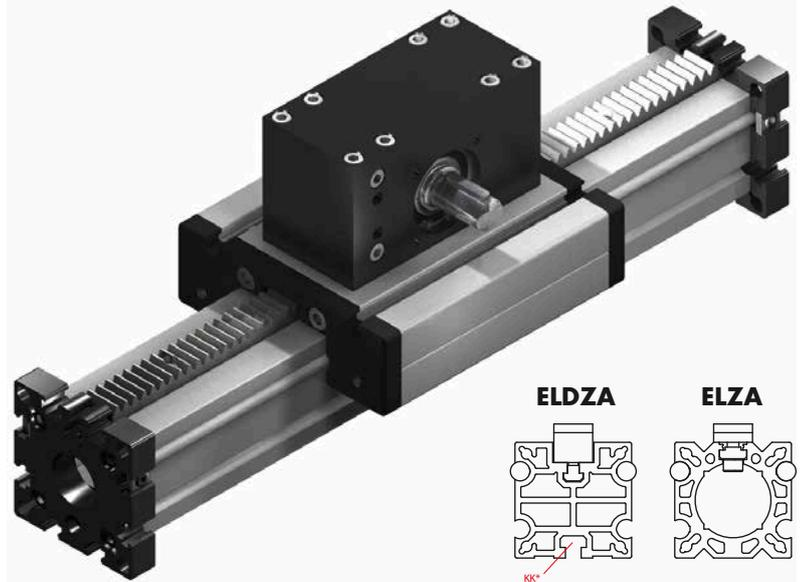

We have been implementing comprehensive model improvement measures so that we are able to offer our products in the segment of toothed rack drives in a more cost-effective and application-oriented way.

New innovative guiding profiles ELDZA have been developed, which can be used effectively in combination with standardized toothed racks. Depending on the specific task (e. g. load, mounting position, service life or cost) it is possible to use different material combinations.

Function:

This unit consists of an aluminium square profile with integrated, hardened steel guide rods. The carriage, which has internal linear ball bearings that can be adjusted free of play, is driven by a rack and pinion. The pinion is equipped with maintenance-free ball bearings.

Fitting position: As required. Max. length without joints 6.000 mm.

Carriage mounting: By T-slots.

Unit mounting: By T-slots and holes in the bearing blocks, mounting sets.

Rack: C45, Steel 1.4305 or plastic (PA 6) possible. Repeatability: ± 0,2 mm.

Forces and torques	Size	ELZA 40		ELDZA 60		ELDZA 60 S		ELDZA 80		ELDZA 80 S		ELDZA 100	
	Forces/Torques	static	dynamic	static	dynamic	static	dynamic	static	dynamic	static	dynamic	static	dynamic
F_x (N)	900	750	1500 *	1200 *	1500 *	1200 *	2200 *	1800 *	2200 *	1800 *	2900 *	2500 *	
F_y (N)	1200	700	3000	2000	4100	3100	3000	2000	4600	3600	8000	6500	
F_z (N)	900	650	1700	1100	2160	1600	1700	1100	3000	1800	3600	2200	
M_x (Nm)	25	20	67	43	88	65	90	55	170	140	300	230	
M_y (Nm)	32	18	90	70	190	140	110	80	270	230	400	270	
M_z (Nm)	35	25	120	100	230	170	150	120	300	220	750	500	
All forces and torques related to the following:													
existing values $\frac{F_y}{F_{y_{dyn}}} + \frac{F_z}{F_{z_{dyn}}} + \frac{M_x}{M_{x_{dyn}}} + \frac{M_y}{M_{y_{dyn}}} + \frac{M_z}{M_{z_{dyn}}} \leq 1$													
table values													
Speed													
(m/s) max	2		2,5		2,5		3		3		3		
Geometrical moments of inertia of aluminium profile													
I_x mm ⁴	1,32x10 ⁵		4,86x10 ⁵		4,86x10 ⁵		18,99x10 ⁵		18,99x10 ⁵		44,4x10 ⁵		
I_y mm ⁴	1,34x10 ⁵		4,87x10 ⁵		4,87x10 ⁵		18,97x10 ⁵		18,97x10 ⁵		44,8x10 ⁵		
E/Modulus N/mm ²	70000		70000		70000		70000		70000		70000		

* = Depending on material combinations (see page 3) F_x values could be different!
For life-time calculation of rollers use our homepage.

Driving torque:

$$M_o = \frac{F \cdot P \cdot S_i}{2000 \cdot \pi} + M_n$$

$$P_o = \frac{M_o \cdot n}{9550}$$

- F = force (N)
- P = pulley action perimeter (mm)
- S_i = safety factor 1,2 ... 2
- M_n = no-load torque (Nm)
- n = rpm pulley (min⁻¹)
- M_o = driving torque (Nm)
- P_o = motor power (KW)

Deflection:

$$f = \frac{F \cdot L^3}{E \cdot I \cdot 192}$$

- f = deflection (mm)
- F = load (N)
- L = free length (mm)
- E = elastic modulus 70000 (N/mm²)
- I = second moment of area (mm⁴)

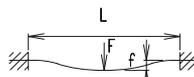

Positioning system ELZA 40 / ELDZA 60, 60S, 80, 80S, 100

Dimensions (mm)

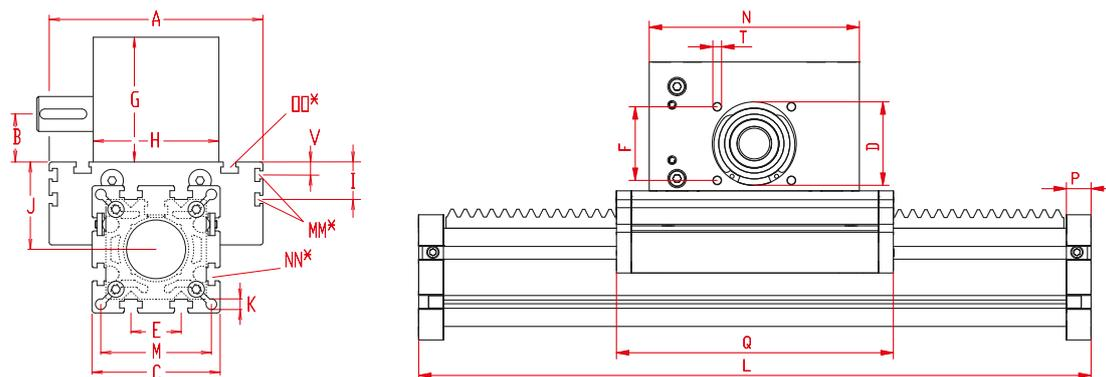

*For slide nuts refer to chapter 2.2 page 2

Increasing the carriage length will increase the basic length by the same amount.

Size	Basic length L	A	B	C	D -0,05	E	F	G	H	I	J	K	KK for	M	MM for	N	NN for	OO for	P	Q	T	V	Basic weight
ELZA 40	150	100	21,5	58	37	18	32	60	56	-	35	6,5	-	47	-	100	M 6	M 6	12	122	M 6	-	2,0 kg
ELDZA 60	205	144	28,0	82	47	30	42	75	63	-	49	8,5	M 6	69	-	130	M 8	M 8	16	168	M 6	-	4,7 kg
ELDZA 60S	230	170	34,5	82	47	30	42	92	63	-	53	8,5	M 6	69	-	150	M 8	M 8	16	194	M 6	10	7,2 kg
ELDZA 80	240	170	39,0	102	68	40	60	105	100	30	70	8,5	-	88	M 6	170	M 10	M 10	20	194	M 8	10	11,9 kg
ELDZA 80S	260	190	39,0	102	68	40	60	105	100	30	71	8,5	-	88	M 6	170	M 10	M 8	20	214	M 8	12,5	12,9 kg
ELDZA 100	360	230	55,3	130	90	50	80	155	120	29	89	10,5	-	112	M 10	240	M 10	M 10	30	300	M 10	-	24,0 kg

0 Choice of guide body profile:

- (0) Standard
- (2) corrosion-protected guide rods and screws (Version 0 and 2)
- (4) expanded corrosion-protected version (Version 1 and 3) (depending on the availability of components)

0 Choice of carriages:

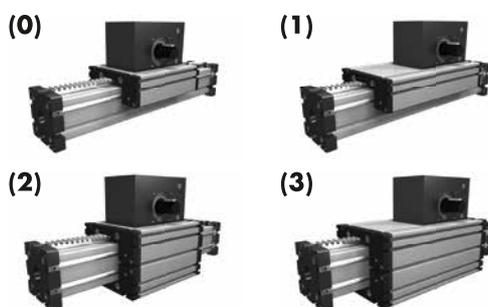

ELZA 40		0,35 kg / 100 mm
ELDZA 60	Polyamide rack	0,56 kg / 100 mm
ELDZA 60	Steel rack	0,78 kg / 100 mm
ELDZA 80	Polyamide rack	0,95 kg / 100 mm
ELDZA 80	Steel rack	1,48 kg / 100 mm
ELDZA 100	Polyamide rack	1,48 kg / 100 mm
ELDZA 100	Steel rack	1,99 kg / 100 mm

Size	Version 1		Version 2		Version 3	
	Q	L	Q	L	Q	L
40	227	255	138	166	243	271
60	303	340	184	221	319	356
60S	349	386	214	251	369	406
80	369	415	210	256	385	431
80S	389	435	234	280	409	455
100	505	565	316	376	521	581

1 Drive version:

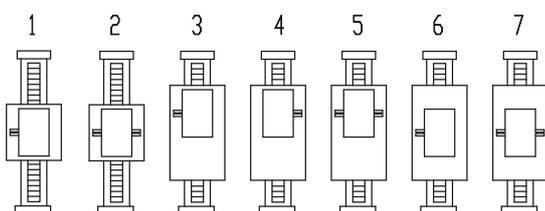

Size	Shaft ø h6 x length	Key	Pinion	
			mm/rev.	Modul
40	14 x 30	5x5x28	188,5	1,5
60	18 x 30	6x6x28	251,3	2
60 S	18 x 30	6x6x28	314,2	2
80 (S)	28 x 40	8x7x35	358,0	3
100	28 x 40	8x7x35	508,9	3

0 Rack/Pinion Version: (ONLY for ELDZA)

Version	0	1	2	3
Material Rack/Pinion	Steel/Plastic (Standard)	Stainless steel/Plastic	Plastic/Steel	Plastic/Stainless steel

1500 Basic length + stroke = total length

For combination kits and connecting elements refer to chapter 2.2

Version 0/1

Version 2/3



ELDZA 60 0 0 0 1 0 3 0 01500

Pos. 1 2 3 4 5 6 7

Sample ordering code:

ELDZA 60 with standard body profile, standard carriage, standard shaft, steel pinion, 1295 mm stroke