

**ATTACCO HSK 63F DIN69893-6
TOOL INTERFACE HSK 63F DIN 69893-6**

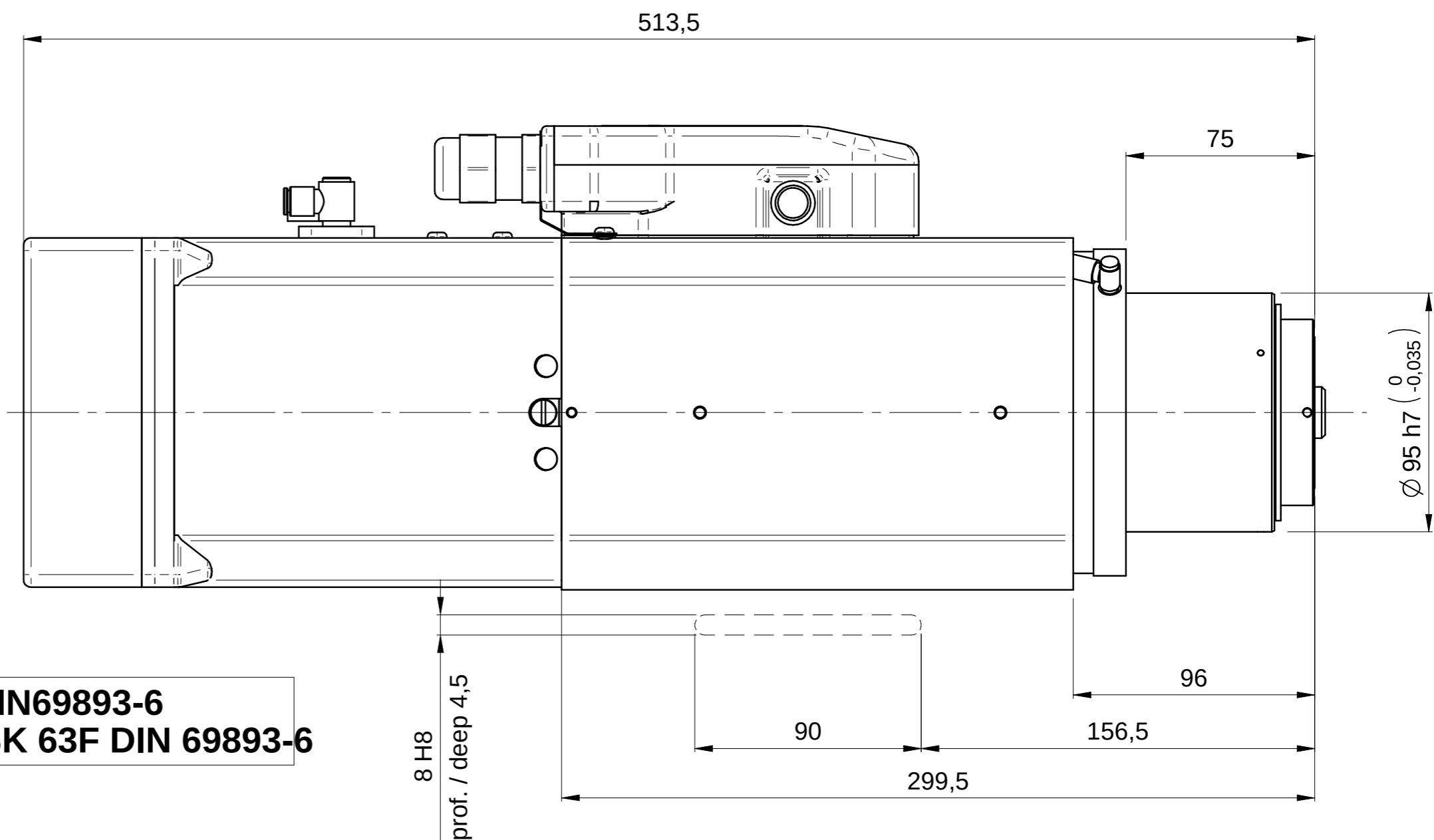

**DETTAGLIO Z
1:1**

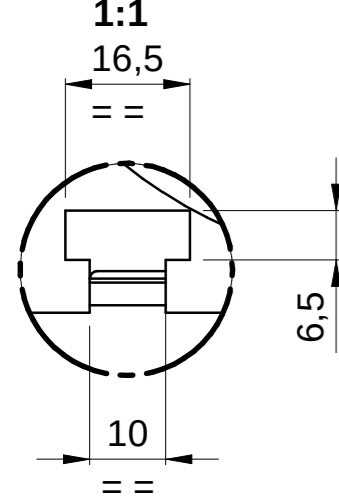

0001351316H PRESSACAVO MET.M16 DIR. X EMC
METALLIC GLAND M16 STRAIGHT FOR EMC

SOFFIO CONO: E6 ARIA SECCA 6 bar
TAPPER CLEANING EG AIR DRY 6 bar

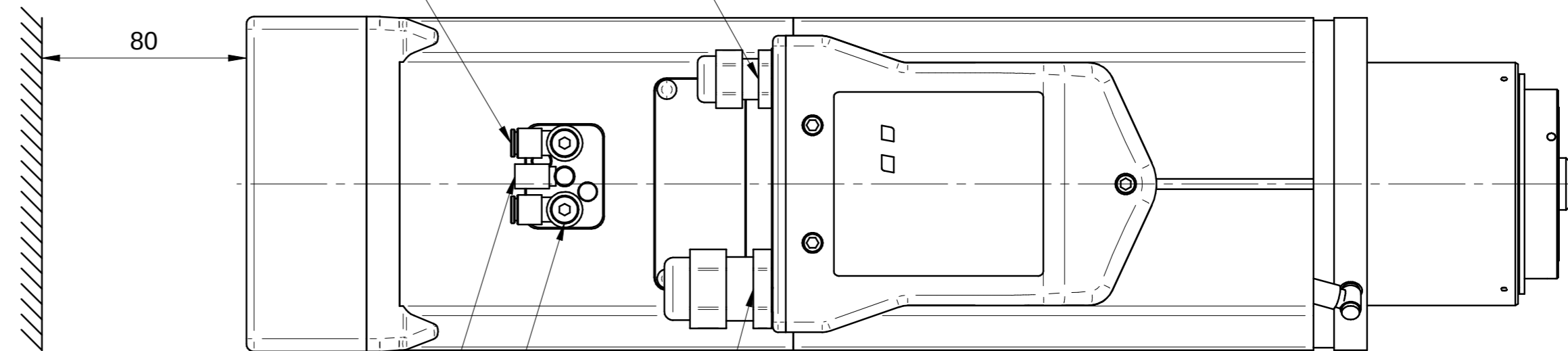

BLOCCO UTENSILE: E4 ARIA SECCA 6 bar
LOOK TOOL : E4 AIR DRY 6 bar

SBLOCCO UTENSILE: E6 ARIA SECCA 6 bar
RELEASE TOOL: EG AIR DRY 6 bar

0001351317A PRESSACAVO MET.M25 DIR. X EMC
METALLIC GLAND M25 STRAIGHT FOR EMC

Massa: 23 Kg

PUNZONARE SU CARCASSA:

EQ XXXX
YY/ZZ

XX=SERIALE
YY=MESE DI PRODUZIONE
ZZ=ANNO SI PRODUZIONE

00										
Rev	Data / Date	Firma / Signature	Descrizione ultima modifica / Last change description		N° Modifica / Change ID					
Caratteristiche tecniche non evidenziate secondo istruzioni operative SCM GROUP Specifications not shown according to SCM GROUP operation instruction				IO 231D1TG		IO 231D1TG		Verniciatura / Painting (SCM specific ST231D1TG)		Superficie / Surface (m²)
Strutture saldate secondo specifica SCM / Welded according to SCM specific : ST232D1G				ST232D1G		ST232D1G		Trattamento Superficiale / Surface Treatment (SCM specific ST234D1G)		
Quote senza indicazione di tolleranza, grado di precisione Shares without indication of tolerance, accuracy				SCM Specifica ST2310DTG		Trattamento Termico / Heat Treatment (SCM specific ST234D1G)				
Ultimo rilascio Latest release		Firma / Signature		Data / Date		Rugosità / Roughness				
Controllato Checked		Fi.Fabrizi		08/10/2014		CF3 0 0		Peso grezzo/Raw weight (kg)		
Disegnato Designed		Fi.Fabrizi		08/10/2014		Smussi / chamfer		Massa / Mass (kg) 47714.302		
Denominazione / Item Name				ELETM QE-1F 10/11 24 63F NC CB DV		Codice / Item ID		Rev 00 Status		
Scala / Scale				1:2		QE.400.A00.01		1/1		

HITECO
HIGH TECHNOLOGY COMPONENTS

Template version: 15

CI RISERVIAMO A TERMINI DI LEGGE LA PROPRIETA' DI QUESTO DISEGNO CON DIVIETO DI RENDERSI O COMUNICARE NOTO A TERZI SENZA LA NOSTRA PREVENTIVA APPROVAZIONE. DRAWING IS SCM PROPERTY. COPYRIGHTED MATERIAL. DISCLOSURE TO THIRD PARTIES WITHOUT OUR AUTHORIZATION IS EXPLICITLY FORBIDDEN.