

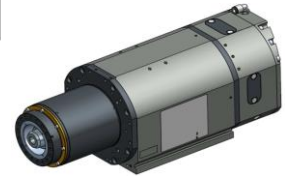

**Electrospindle ATC 18Kw 24.000 rpm  
PX-2 18/12 24 63F NL**

**PX.X00.L01**

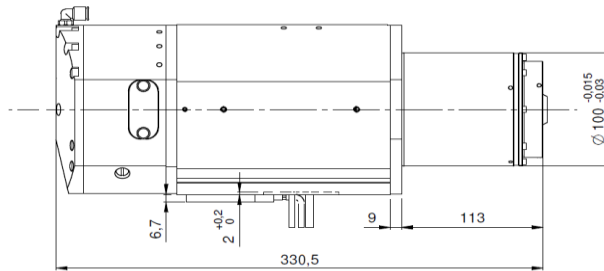
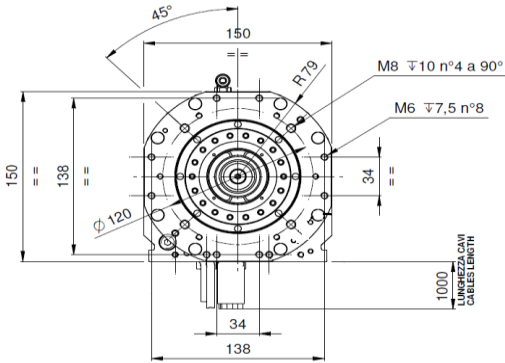

**Prestazioni - Performances**

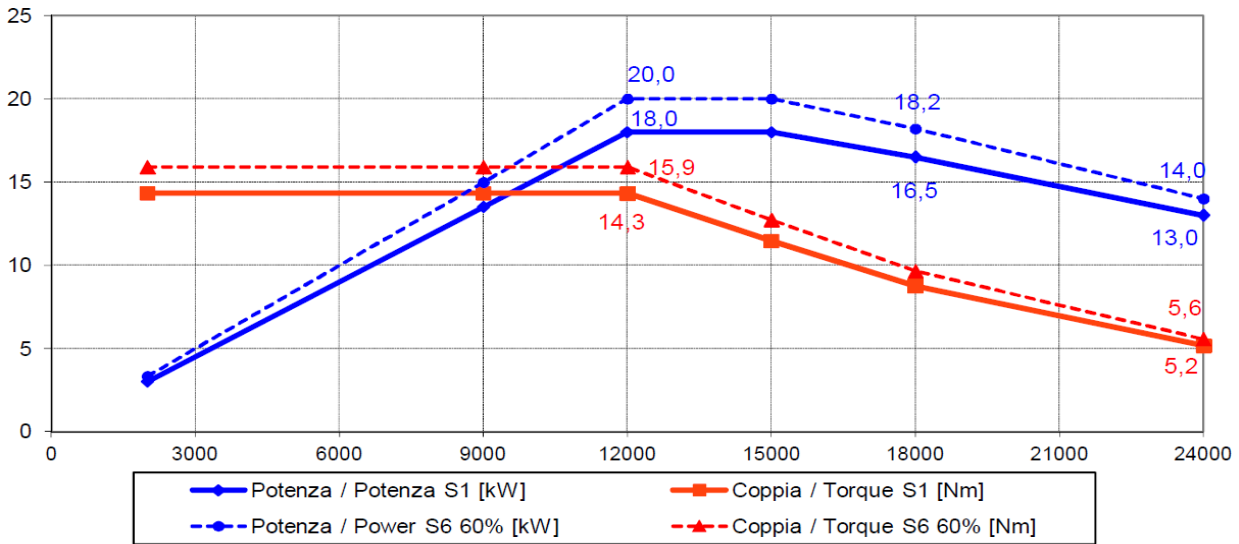

**Specifiche tecniche/ Technical Specifications**

**Tipologia elettromandrino / Electrospindle type**

**Attacco utensile / Tool interface**

**Velocità rotazione max / Max speed**

**Raffreddamento / cooling**

**Cuscinetti / Ball bearings**

**Lubrificazione cuscinetti / Bearings lubrication**

**Connessione pneumatiche / Pneumatic connection**

**Potenza max. (S1 - S6) / Max. Power.(S1 - S6)**

**Coppia max. (S1 - S6) / Max. Torque (S1 - S6)**

**Corrente (S1 - S6) / Current (S1 - S6)**

**Tensione / Voltage**

**Rotazione / Rotation**

**Azionamento / Supply**

**Sensoristica / Sensors**

**Peso / Weight**

Asincrono-4 poli / Asynchronous-4poles

HSK 63F

24000 rpm

Liquido / Liquid

Ceramici / Ceramic

Grasso a vita / Grease long life

Sblocco uten. / Release. tool: Ø5 9,5-10,5 bar

Pressurizzazione / Air seal. Ø5 4-4,5 bar

Soffio cono-aria utensile / Taper cleaning-air tool Ø5 4-4,5 bar

18 kW @12000 Rpm (S1) / 20 kW @ 12000 Rpm (S6)

14,3 Nm (S1) / 15,9 Nm (S6)

35 A (S1) / 38.5 A (S6)

380 V

CW - CCW

Con inverter / By inverter

S1 Afferraggio utensile / S1 Tool lock

S2 Pinza aperta / S2 Open clamp

S3 Rotazione albero / S3 Spindle rotation

25 kg